

# SUNVISION *Elite*™ 48V

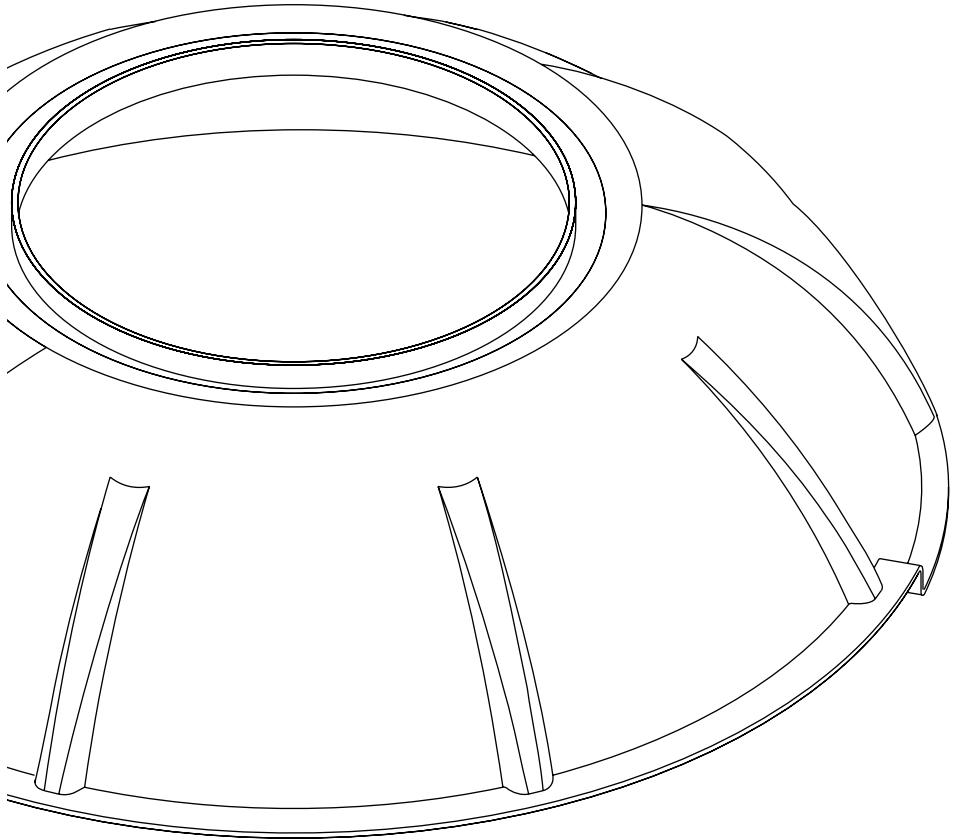

26851-01A

## STANDARD 24 MONTH WARRANTY

Your ETS Distributor (including ETS, Inc. if purchased directly), through a manufacturer's warranty, warrants your tanning unit to be free of structural defects in material and workmanship, under normal use, for its lifetime. Your ETS Distributor will, at its discretion, repair any structural defect which materially affects the performance of the tanning unit, or replace the tanning unit.

For twenty-four (24) months following the shipping date of your tanning unit, your ETS Distributor will provide replacements for parts that prove to be defective in material or workmanship. Fluorescent lamps, and lamp starters are warranted against manufacturer's defects for a period of ninety (90) days following the shipping date of your tanning unit. Acrylics will be warranted against manufacturer's defects for a period of 1 year (prorated).

Labor costs associated with repair or replacement work covered by this warranty will be reimbursed for repair or replacement work required to be performed for a period of one (1) year following the shipping date of your tanning unit. Normal wear and tear, damage from misuse or abuse, damage incurred in transit or damages resulting from unauthorized repairs or modifications are not covered by this warranty. Warranty coverage does not include cosmetic abnormalities such as scratches, nicks, dents, or other cosmetic changes that do not materially interfere with the function of the tanning unit.

THIS STANDARD 24 MONTH WARRANTY IS EXPRESSLY MADE IN LIEU OF ANY OTHER WARRANTIES, EXPRESS OR IMPLIED, INCLUDING ANY IMPLIED WARRANTIES OF MERCHANTABILITY AND FITNESS FOR A PARTICULAR PURPOSE, WHICH ARE HEREBY DISCLAIMED. No one has the authority to change or modify this Standard 24 Month Warranty in any respect. To obtain service under this Standard 24 Month Warranty, contact your authorized ETS Distributor (or ETS, Inc. if purchased directly). Proof of purchase, including serial number, is required.

IN NO EVENT SHALL YOUR DISTRIBUTOR OR THE MANUFACTURER BE LIABLE AT LAW OR IN EQUITY FOR ANY LOSS, LIABILITY, DAMAGE OR EXPENSE IN AN AMOUNT IN EXCESS OF THE PURCHASE PRICE RECEIVED, OR FOR LOSS OF USE OR PROFITS, LOSS OF TIME, INCONVENIENCE, RENTAL OR SUBSTITUTE PRODUCTS, LOSS OF BUSINESS, LOSS OF INCOME, OR ANY OTHER INCIDENTAL, INDIRECT, SPECIAL OR CONSEQUENTIAL DAMAGES. Some states do not allow the exclusion or limitation of incidental or consequential damages, and the above limitation or exclusion will not apply to residents of some states. This Standard 24 Month Warranty gives you specific, legal rights and you may have other rights which may vary from state to state.

All warranty service must be performed by an authorized service person. All labor charges must be authorized by your ETS Distributor prior to the start of repairs and must not exceed the established rates and time allotment policies established by your ETS Distributor. If your tanning unit must be returned for service, all freight charges shall be at your expense. Contact your ETS Distributor for the authorized Service Center nearest you. This warranty is serial number specific and only applies to tanning units purchased through an authorized ETS Distributor. This warranty is extended to the individual or legal entity whose name appears on the original sales document and may not be transferred to any other individual or legal entity. This warranty is void if the tanning unit is modified in any manner from its original design.

**To obtain warranty service, contact your place of purchase. Proof of purchase, including serial number, is required for verification. Contact ETS, Inc. only if you purchased your equipment directly.**

**ETS, Inc. 7445 Company Drive, Indianapolis, IN 46237-9296  
1-800-449-3605 In Canada call 1-800-661-6292 or 519-421-1212**



# elcome

---

Congratulations on your purchase of this technologically advanced sun tanning unit. It has been designed to provide years of dependable service for you.

Please read all the instructions in this booklet before installing and using the unit. Always be sure to observe all safety precautions.

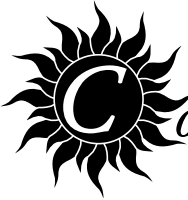

# ontents

---

<b>Safety Information</b> .....	<b>.iii</b>
<b>Installation</b> .....	<b>1</b>
Unpacking and Inspection .....	1
Pre-Installation Planning .....	2
Tools Required .....	3
Hardware Inventory .....	3
Assembly Procedures .....	5
Electrical Connections .....	19
Remote Connections .....	20
<b>Operation</b> .....	<b>23</b>
Before You Tan .....	23
Exposure Times .....	23
Using Your Booth .....	24
<b>Care and Maintenance</b> .....	<b>26</b>
Cleaning After Use .....	26
Thorough Periodic Cleaning .....	26
Hour Counter .....	27
Mechanical Inspection .....	27
Lamp and Grill Maintenance .....	28
<b>Troubleshooting</b> .....	<b>29</b>



# Safety Information

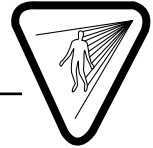

**LABELING NOTICE:** Labels are affixed on all systems to inform the user of possible dangers. Regulations are stated in 21 CFR, Section 1040.20, and require that all products manufactured after September 8, 1986 which use sunlamps must display the following:

**DANGER** Ultraviolet radiation. Follow instructions. Avoid overexposure. As with natural sunlight, overexposure can cause eye and skin injury and allergic reactions. Repeated exposure may cause premature aging of the skin and skin cancer. **WEAR PROTECTIVE EYEWEAR; FAILURE TO MAY RESULT IN SEVERE BURNS OR LONGTERM INJURY TO THE EYES.** Medications or cosmetics may increase your sensitivity to the ultraviolet radiation. Consult physician before using sunlamp if you are using medications or have a history of skin problems or believe yourself especially sensitive to sunlight. If you do not tan in the sun, you are unlikely to tan from the use of this product. Children, the elderly, or fair skinned people who always burn easily and either never tan or tan minimally should not use this equipment.

For a uniform tan, center yourself within the booth both front and back and to the left and right. This will result in your body being equidistant from all lamps. Other positions may result in overexposure to parts of your body. Do not use without metal grids in place. Untanned persons should not tan on consecutive days during their first week of tanning. Never tan more than once a day. Tanning normally appears after the first few sessions and maximizes after approximately four weeks. Tan once or twice per week thereafter to maintain appearance. Persons already having a base tan may begin at advanced levels corresponding to the extent of their base tan.

RECOMMENDED EXPOSURE TIMES IN MINUTES		MAXIMUM EXPOSURE TIME IS 12 MINUTES				
Skin Type:		Level 1/Week 1 1st-3rd Sessions	Level 2	Level 3	Level 4	Subsequent Maximum
I Sensitive Skin (Burns easily and severely and does not tan.)		NOT RECOMMENDED FOR TANNING				
II Light	(Burns easily and severely and tans minimally.)	2	4	7	10	12
III Normal	(Burns moderately and tans average.)	3	6	9	12	12
IV Dark	(Burns minimally, tans easily and above average.)	4	7	10	12	12

New lamps emit approximately 10% more ultraviolet radiation during the first 50 hours of operation. Recommended tanning times should therefore be reduced by approximately 10% during that period.

**WARNING:** • Read the instructions booklet before using this sunlamp product. • All persons in the room should wear protective eyewear when lamps are on. Recommended eyewear: provided eyeshields or equivalent eyewear as defined under 21 CFR 1040.20. Other types of eyewear may not provide adequate protection. Failure to use protective eyewear may result in severe burns or other eye injury. If discomfort develops, discontinue use and consult a physician.

**THE FOLLOWING LAMPS HAVE BEEN CERTIFIED FOR USE IN THIS EQUIPMENT:**  
**BRONZING SUN™ Wolff® Model BS71-T12-160W VS-R BI-PIN**

**DISCONNECT POWER BEFORE ATTEMPTING TO CLEAN, RELAMP, OR ENGAGE IN THE MAINTENANCE OF THIS PRODUCT.**

THIS EQUIPMENT MUST BE EARTH GROUNDED.

This product is in conformity with performance standards for sun lamp products under 21 CFR PART 1040.20 and ANSI/UL Standard 482. Certified to CAN/CSA Standard C22.2 NO. 224.





**DANGER** Rayonnement ultraviolet. Veuillez suivre les instructions. Évitez une exposition excessive; tout comme pour les rayons du soleil, une exposition excessive peut causer des blessures aux yeux et à la peau et provoquer des réactions allergiques. Une exposition répétée peut causer le vieillissement prématuré de la peau et provoquer le cancer de la peau. **PORTEZ DES LUNETTES PROTECTRICES: LE NON-RESPECT DE CETTE CONSIGNE DE SÉCURITÉ PEUT ENTRAÎNER DE GRAVES BRÛLURES OU DES LÉSIONS OCULAIRES À LONG TERME.** Les médicaments ou les produits cosmétiques peuvent augmenter votre sensibilité au rayonnement ultraviolet. Consultez un médecin avant d'utiliser la lampe solaire si vous prenez des médicaments, si vous souffrez d'une maladie cutanée ou si vous croyez être particulièrement sensible aux rayons du soleil. Si vous ne bronzez pas au soleil, il est peu probable que vous bronzez sous une lampe solaire. Les enfants, les personnes âgées et les personnes qui ont une peau claire qui brûle facilement, ne bronze jamais ou alors très peu, ne devraient pas utiliser cette lampe.

Pour un bronzage uniforme, placez-vous au centre du compartiment (aussi bien de l'avant à l'arrière que sur les côtés). Ainsi, le corps sera à distance égale de toutes les lampes. Un mauvais alignement peut causer une exposition excessive de certaines parties du corps. N'utilisez pas la lampe sans les grilles en fil métallique. La première semaine de bronzage, les personnes qui n'ont pas un hâle initial ne doivent pas se faire bronzer tous les jours. Ne vous faites jamais bronzer plus d'une fois par jour. Le bronzage commence normalement à apparaître après les premières séances : il atteint son apogée au bout d'environ quatre semaines. Les personnes qui ont déjà un teint hâlé peuvent commencer à des niveaux plus élevés, selon l'importance de leur hâle initial.

TEMPS D'EXPOSITION RECOMMANDÉ EN MINUTES		LE TEMPS D'EXPOSITION MAXIMAL EST DE 12 MINUTES				
Type de peau:	Élevé 1/1 <sup>ère</sup> - 3 <sup>e</sup> Semaine	Élevé 2	Élevé 3	Élevé 4	Sem. suivantes Temps maximal	
I <b>Peau sensible</b> (brûle facilement et ne bronze pas)	<b>NON RECOMMANDÉ</b>					
II <b>Peau claire</b> (brûle facilement et bronze très peu)	2	4	7	10	12	
III <b>Peau normale</b> (brûle et bronze de façon modérée)	3	6	9	12	12	
IV <b>Peau foncée</b> (brûle très peu, bronze plus facilement que la moyenne) <sup>4</sup>		7	10	12	12	

Les lampes neuves émettent approximativement 10 % de plus de rayons ultraviolets au cours des 50 premières heures de fonctionnement. Le temps de bronzage doit donc être réduit d'environ 10 % pendant cette période.

**AVERTISSEMENT :** • Lisez le livret d'instructions avant d'utiliser cette lampe solaire. • Les autres personnes présentes dans la pièce doivent aussi porter des lunettes protectrices lorsque les lampes sont allumées. Coquilles de protection pour les yeux recommandées: Les coquilles de protection fournies ou l'équivalent, tel que le stipule le document 21 CFR 1040.20. Les autres types de lunettes protectrices peuvent ne pas assurer une protection adéquate. Utilisé sans lunettes protectrices, ce produit peut causer des brûlures ou lésions oculaires graves. Si vous souffrez d'un malaise, arrêtez l'utilisation et consultez un médecin.

**SEULES LES LAMPES INDIQUÉES CI-DESSOUS ONT ÉTÉ HOMOLOGUÉES POUR CET ÉQUIPEMENT:  
BRONZING SUN™ Wolff® Modèle BS71-T12-160W VS-R BI-PIN**

**Débrancher l'alimentation électrique avant de nettoyer l'appareil, d'en faire l'entretien ou de changer les lampes.**



Cet équipement doit être mis à la terre.

Ce produit est conforme aux normes de rendement pour les lampes solaires dans le documents 21 CFR, partie us 1040.20, ANSI/UL 482, CAN/CSA C22.2 N° 224.



# *Installation*

---

## **Unpacking and Inspection**

The SUNVISION Elite™ 48V arrives in seven boxes. For ease of assembly, after inspection leave everything in its box until called for in the assembly instructions.

Open each box and inspect the contents and make sure they are free from any visible damage. Report the extent of any damage to the transportation company.

As you unpack your boxes you should find the following:

- Pedestal (box 1)
- Control Module (box 2)
- Bag containing necessary assembly hardware, and safety goggles (box 2)
- Left Module (box 3)
- Right Module (box 4)
- Left Door (box 5)
- Right Door (box 6)
- Dome Assembly (box 7)
- Two Long Handles
- Two Long Trim Profiles
- Timer Assembly (box 7)

Record the serial number of the control module in the area provided at the back of this manual. This information will be required if you ever need to call customer service.

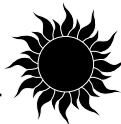

## Pre-Installation Planning

Before you begin to assemble your booth, you should observe the following considerations.

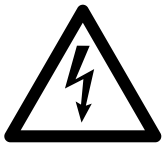
	<b>⚠ WARNING</b>
	<b>Shock hazard. Disconnect power before servicing.</b>

<b>⚠ CAUTION</b>
<b>Use of a voltage source above 230V AC may prevent proper operation of the booth and could cause damage and void the warranty.</b>

- The **SUNVISION Elite™ 48V** operates from a 220V AC power source. The unit should be hardwired directly to a junction box on a dedicated circuit capable of providing **60 Amp** service. We recommend connection by a professional electrician.
- **IMPORTANT!** Voltage must be below 230V AC or may require a Buck Booster.

<b>⚠ CAUTION</b>
<b>Air from the room is used to cool the unit. Maximum ambient room temperature should be 80°F. Place your booth no closer than 6" from any wall. Make sure nothing obstructs the airflow into or out of the fan openings. A poorly ventilated room may cause the unit to become hot and cause discomfort to the user.</b>

<b>⚠ CAUTION</b>
<b>Proper assembly of your booth requires two people. Plan to have a helper or two assist you.</b>



## Tools Required

You will need the following tools to assemble your booth.

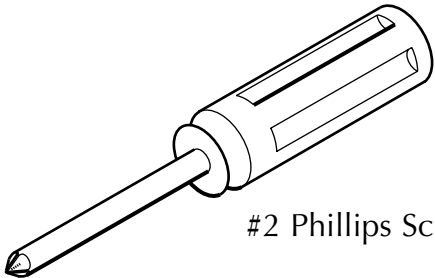

#2 Phillips Screwdriver

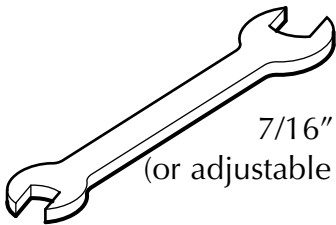

7/16" Wrench  
(or adjustable wrench)

## Hardware Inventory

Open the hardware bag and remove the hardware. Make sure you have the following items.

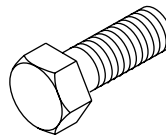

1/4-20 x 3/4"  
Hex Head Bolt  
Quantity - 9

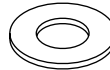

1/4" Flat Washer  
Quantity - 9

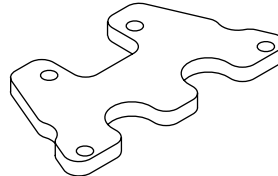

Joint Plate  
Quantity - 2

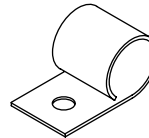

Wire Clamp  
Quantity - 2

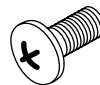

#10-32 x 1/2" Screw  
Quantity - 16



#10-32 Flange Nut  
Quantity - 4

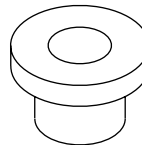

Bronze  
Hinge Bushing  
Quantity - 4



Hinge Locking Pin  
Quantity - 4

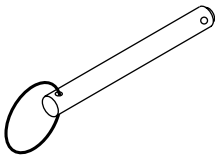

Magnet  
Strike Plate  
Quantity - 2

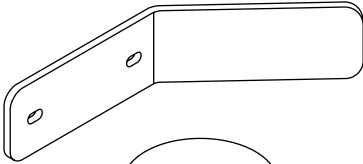

Shim Washer  
Quantity - 4

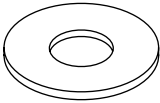

Inside Door Handle  
Quantity - 2

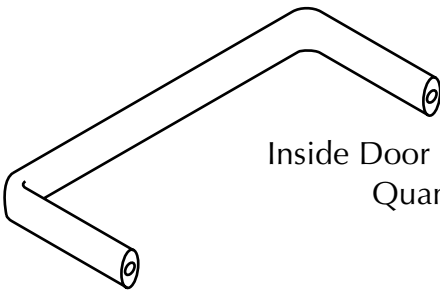

Safety Goggles  
Quantity - 1

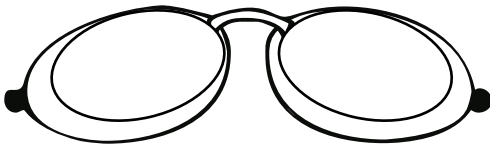

**Additional hardware found in Box 7**

#10-32 x 1/2" Screw  
Quantity - 4

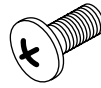

#8-32 x 1/2" Screw  
Quantity - 4



#10 x 1/2" Screw  
Quantity - 4

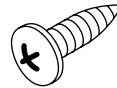

#10 Flat Washer  
Quantity - 4



Short "Z" Bracket  
Quantity - 2

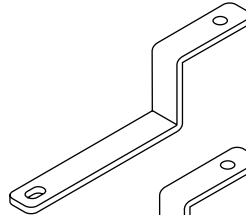

Tall "Z" Bracket  
Quantity - 2

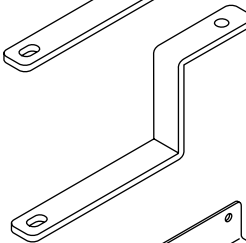

Timer Bracket  
Quantity - 1

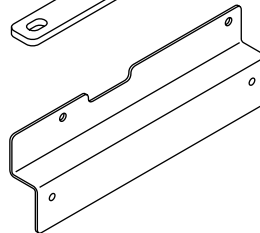



## **Assembly Procedures**

Put the pedestal (found in *box 1*) in the general area you want the booth. Leave some space around the pedestal to work.

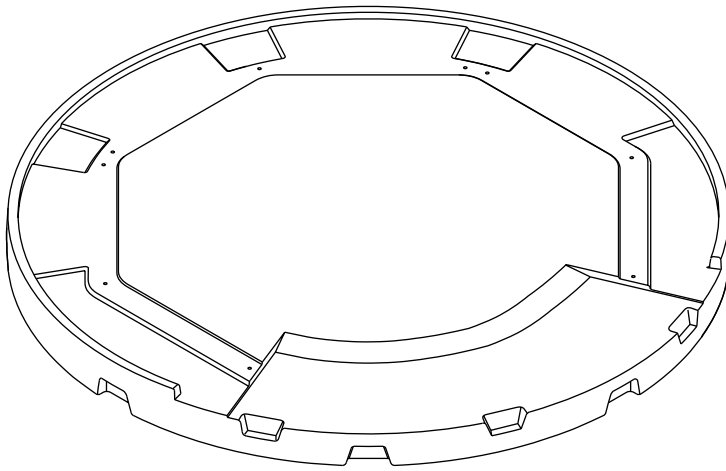

FRONT



Parts needed:

Control Module (box 2)

Left Module (box 3)

Right Module (box 4)

CONTROL MODULE  
(with power cable on back)

Remove these two screws and lift the grill from the unit. Repeat for the other grills.

LEFT MODULE

NOTE: Wiring has been deleted to show details.

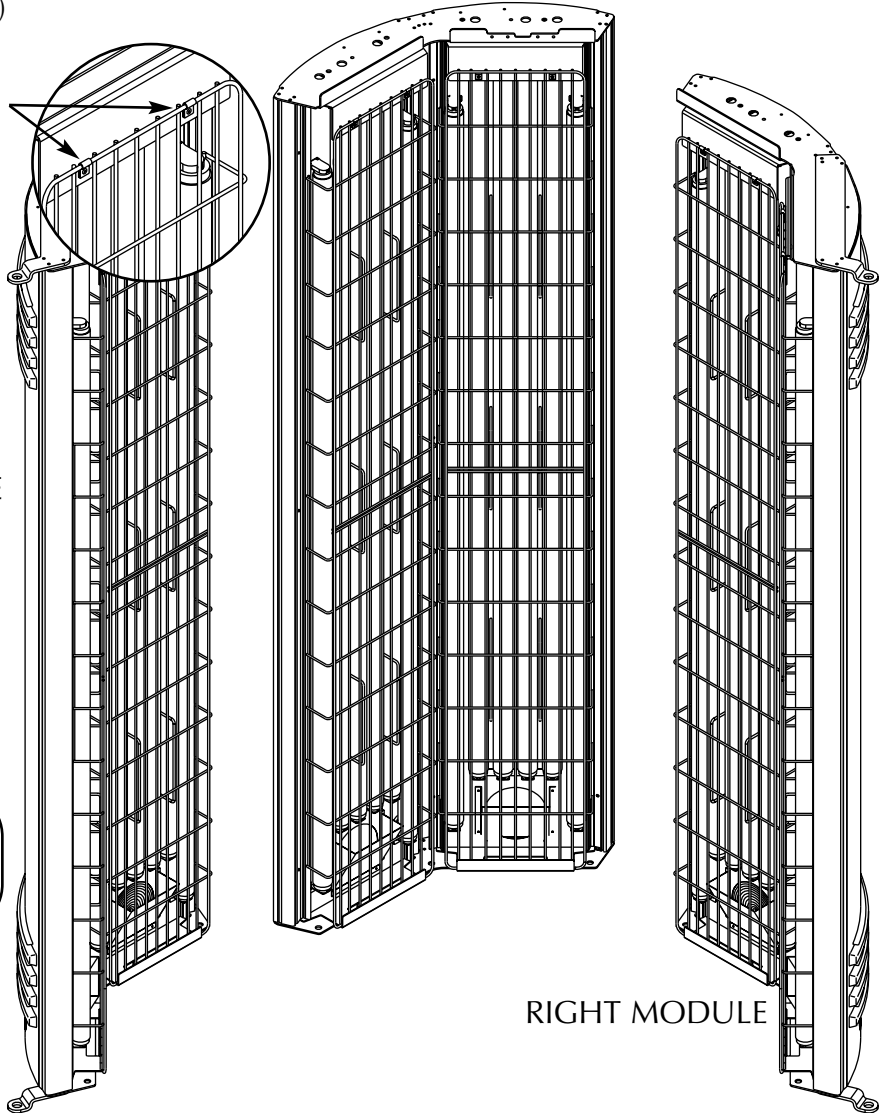

RIGHT MODULE



Parts needed:

Control Module

Left Module

Right Module

9 - 1/4-20 x 3/4" Hex Head Bolts

9 - 1/4" Flat Washers

Attach modules to pedestal with three bolts and washers each, as shown. Attach the Control Module (center module) first, then the other two. Leave the bolts slightly loose until all are positioned, then tighten. For best results, push the left and right modules apart as much as possible. This will help when installing the doors.

NOTE: Wiring has been deleted to show details.

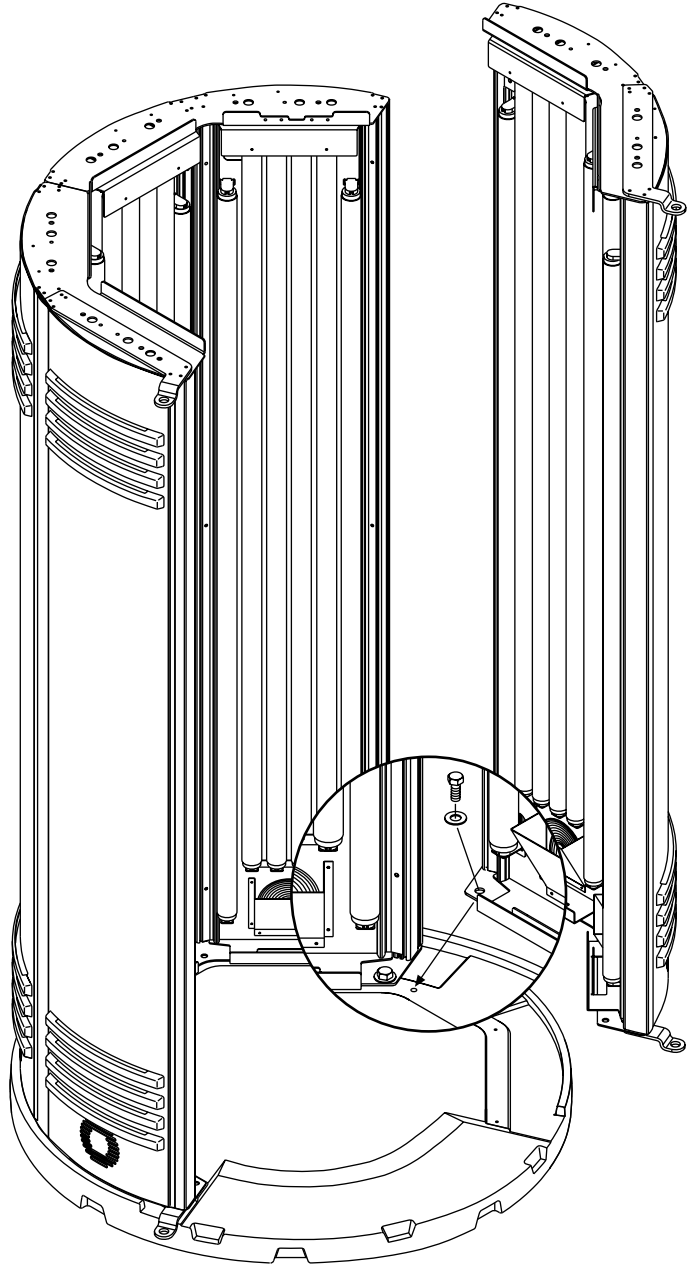



- Parts needed:  
2 - Joint Plates  
2 - Wire Clamps

Remove these four screws and secure the joint plate with them as shown at left.

Secure one wire clamp to each joint plate.

Joint Plate in place.

NOTE: Wiring has been deleted to show details.

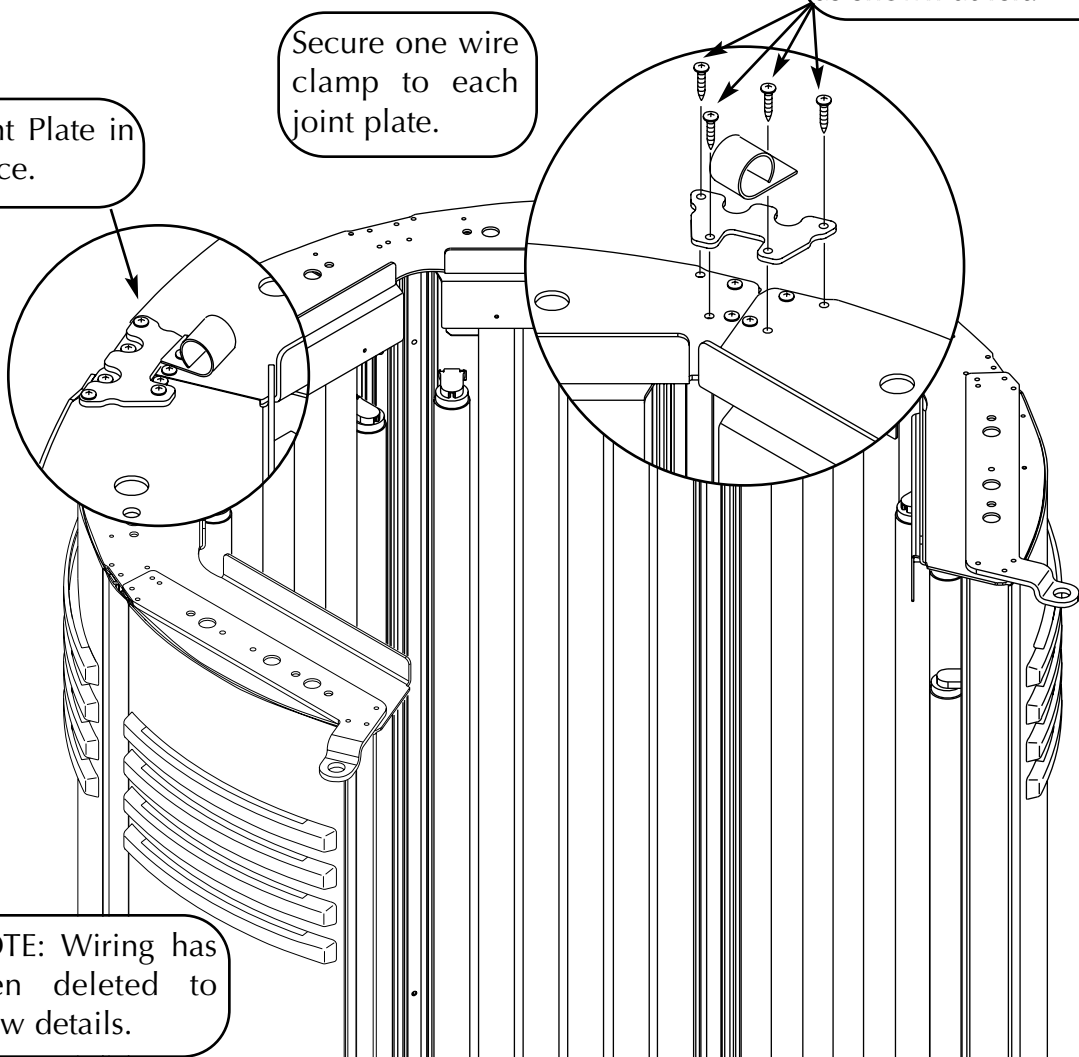



Parts needed:

2- Inside Door Handles

4 - #10-32 x 1/2" Screws

1

If not already done, you will need to remove the grills from both doors.

2

Secure handles with screws through the double grid pattern on each door grill.

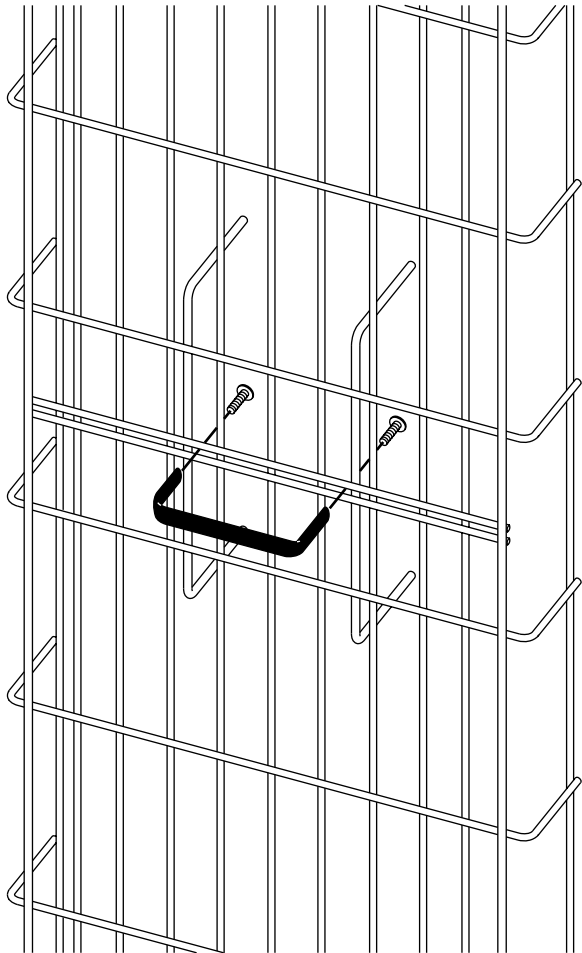



Parts needed:  
Grills (removed earlier)  
2 - Trim Profiles

Reinstall the grills.

Insert trim profiles into space between right and control module, and between left and control module.

NOTE: Wiring has been deleted to show details.

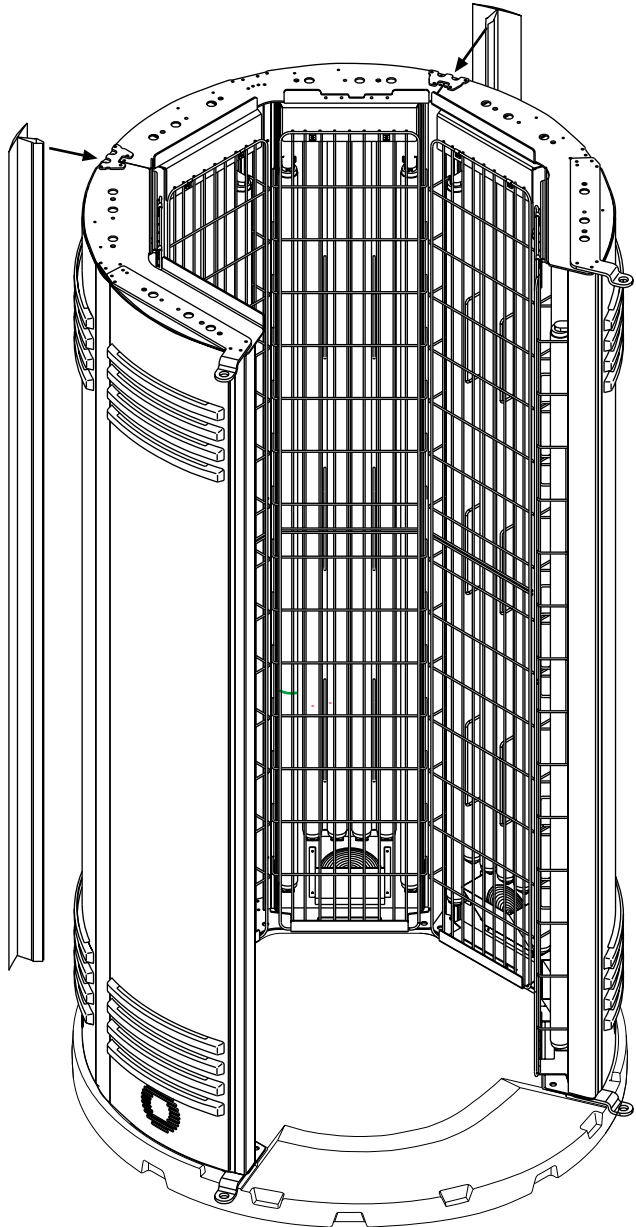



Parts needed:

Timer Assembly (box 7)

Timer Bracket

4 - #8-32 x 3/4" Screws

Attach the Timer Bracket to the unit, as shown, using two #8-32 x 1/2" screws. Secure the Timer Box to the bracket with the same type screws, making sure the cables coming out the back of the Timer Box run over the bracket. Connect the cables to the mating cables on top of the booth.

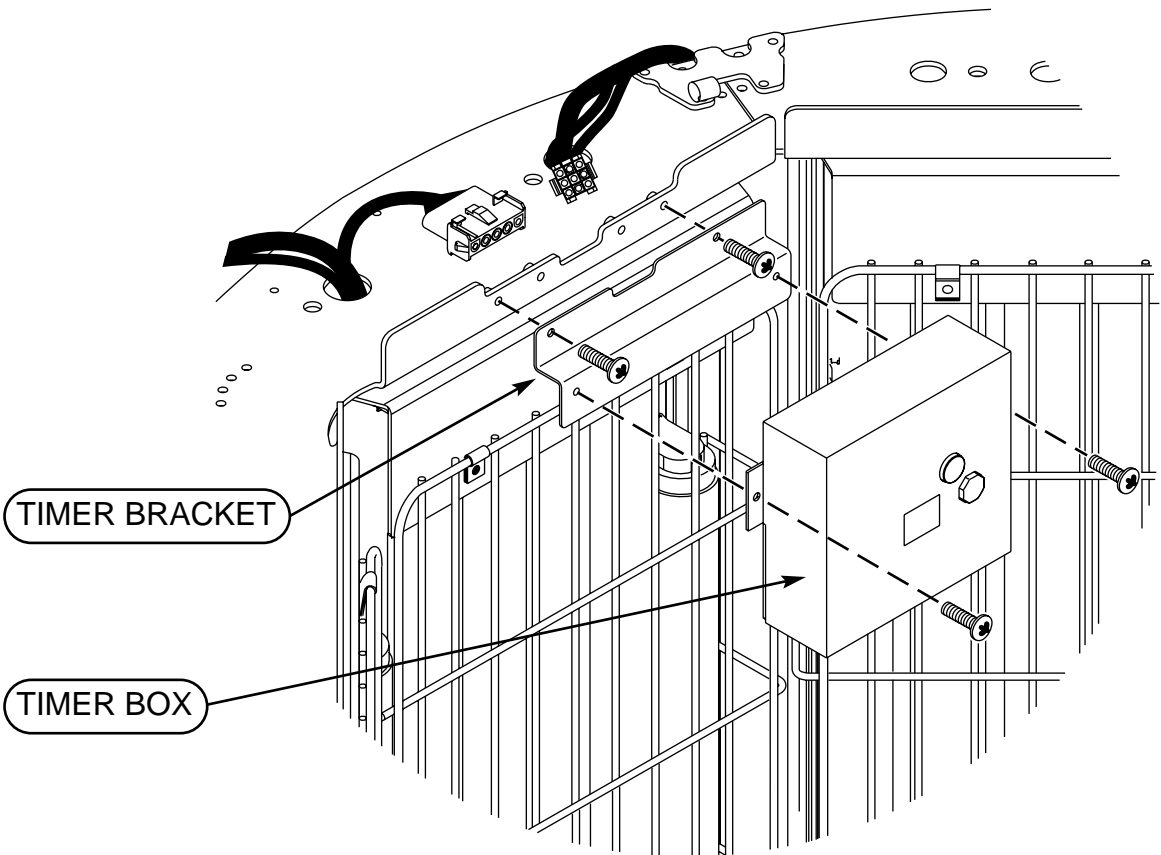



Parts needed:

Long Handles

8 - #10-32 x 1/2" Screws

4 - #10-32 Nuts

The handles attach with two screws to the top of the right and left modules and with two screws with nuts through the double grill wire at the bottom, as shown.

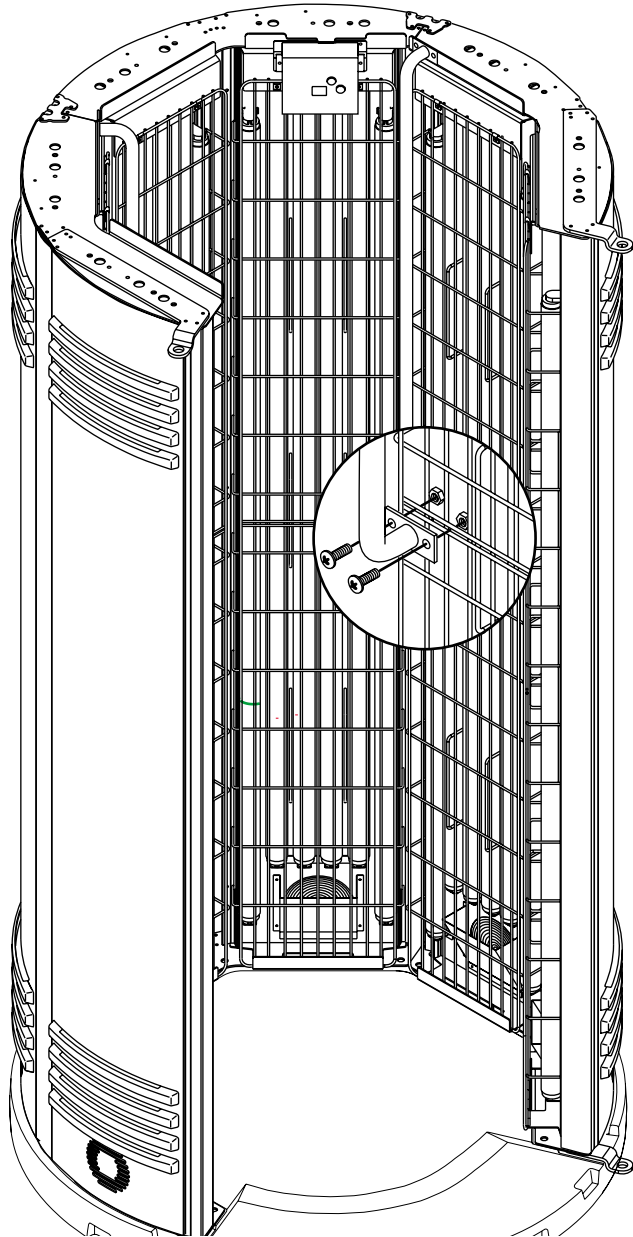



Parts needed:

Left Door (box 5)

Right Door (box 6)

4 - Hinge Bushings

4 - Hinge Locking Pins

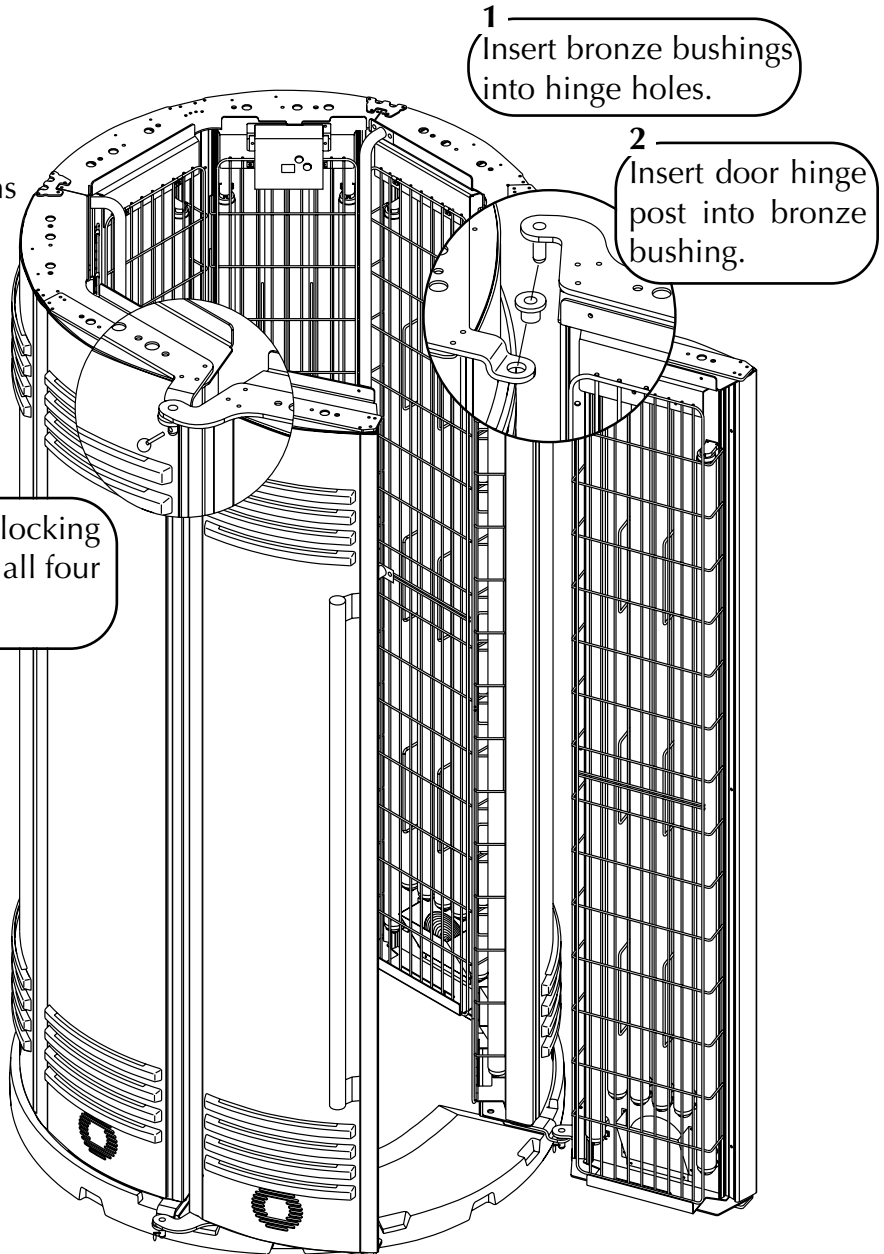

If a door rubs the pedestal, install a shim washer on the hinge post over the bronze bushing on both the upper and lower hinges of the affected door.

NOTE: Wiring has been deleted to show details.



Parts needed:

2 - Magnet Strike Plates

4 - #10-32 x 1/2" Screws

Install magnet strike plates with two screws each. To achieve proper positioning, close the doors and make sure magnets at the top of the doors contact the magnet strike plates.

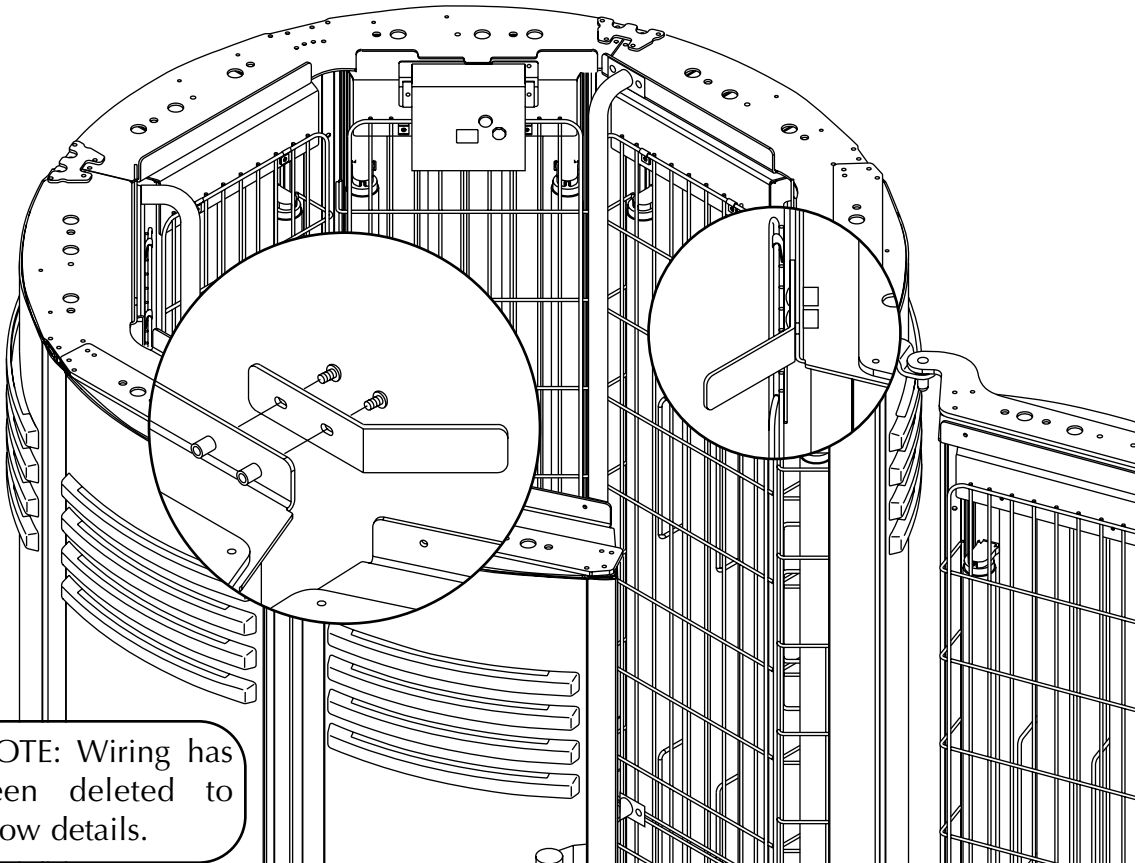



There are six cables coming out of the top of the control unit (not counting the two connected to the Timer Assembly). Four have black, three hole female connectors. One has a white three hole female connector. The last cable has a woven sleeve and small six pin connector. These last two should be left loose. Wire the booth by plugging the connectors on top of each module to these, making sure all wiring is secured in any wire clamp it may pass.

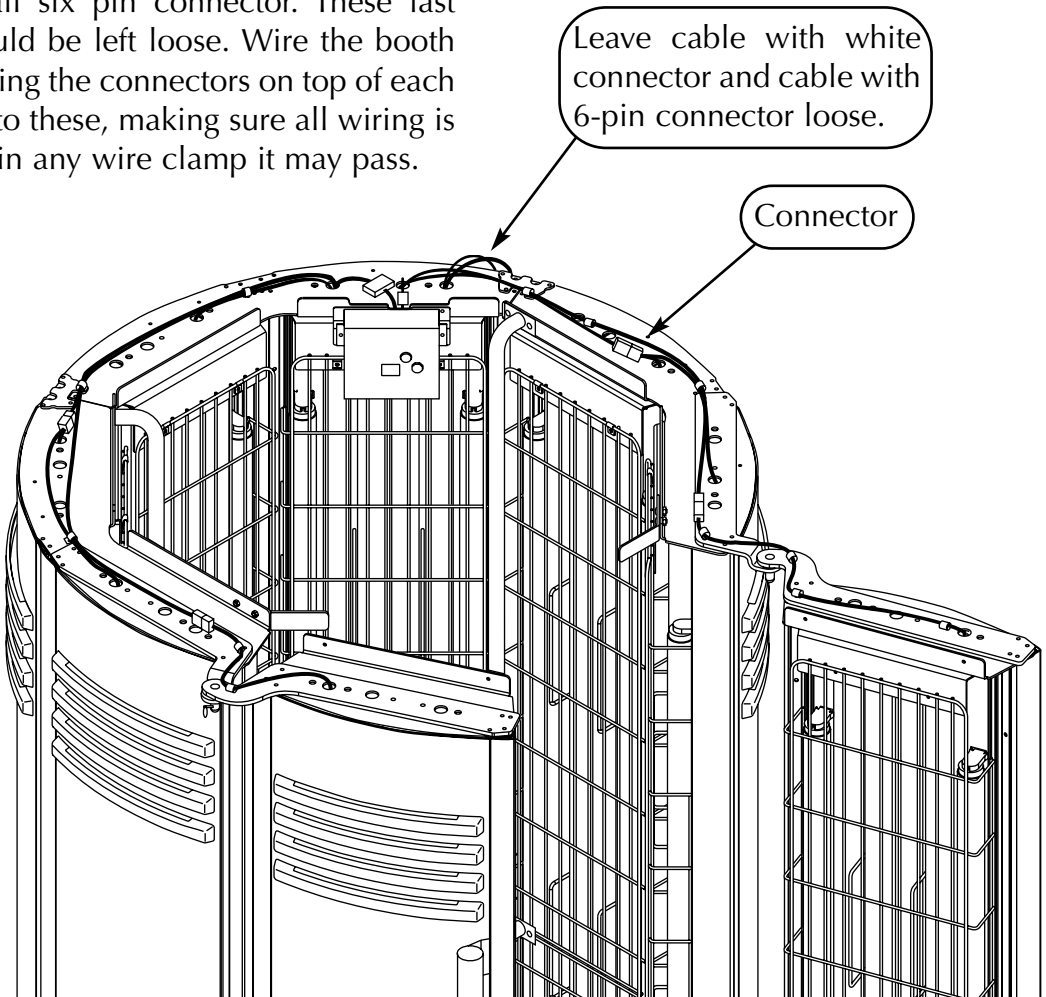



Parts needed:

Body Fan / Speaker Panel (box 7)

2 - Short "Z" brackets

2 - Tall "Z" brackets

8 - #10-32 x 1/2" screws

Position the new body fan / speaker panel on top of the booth, with the curved edge toward the door opening. There are four "Z" brackets. Two are slightly shorter than the others (see illustration). Use these, and the #10-32 x 1/2" screws, to secure the panel in place in the front. Use the taller brackets in the back.

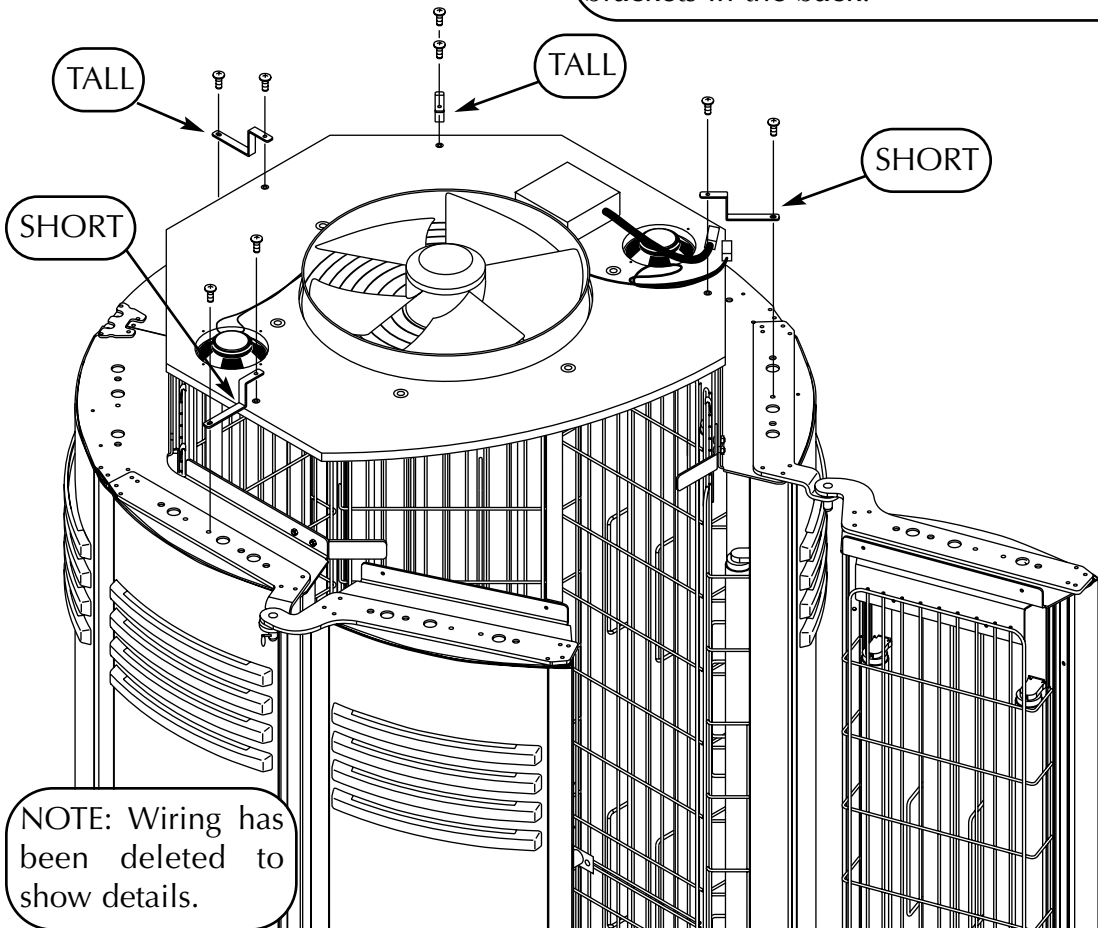



The two cables left loose earlier go to the Body Fan / Speaker Panel. Bring the cables through any wire clamps they pass and connect to the mating cables on the panel.

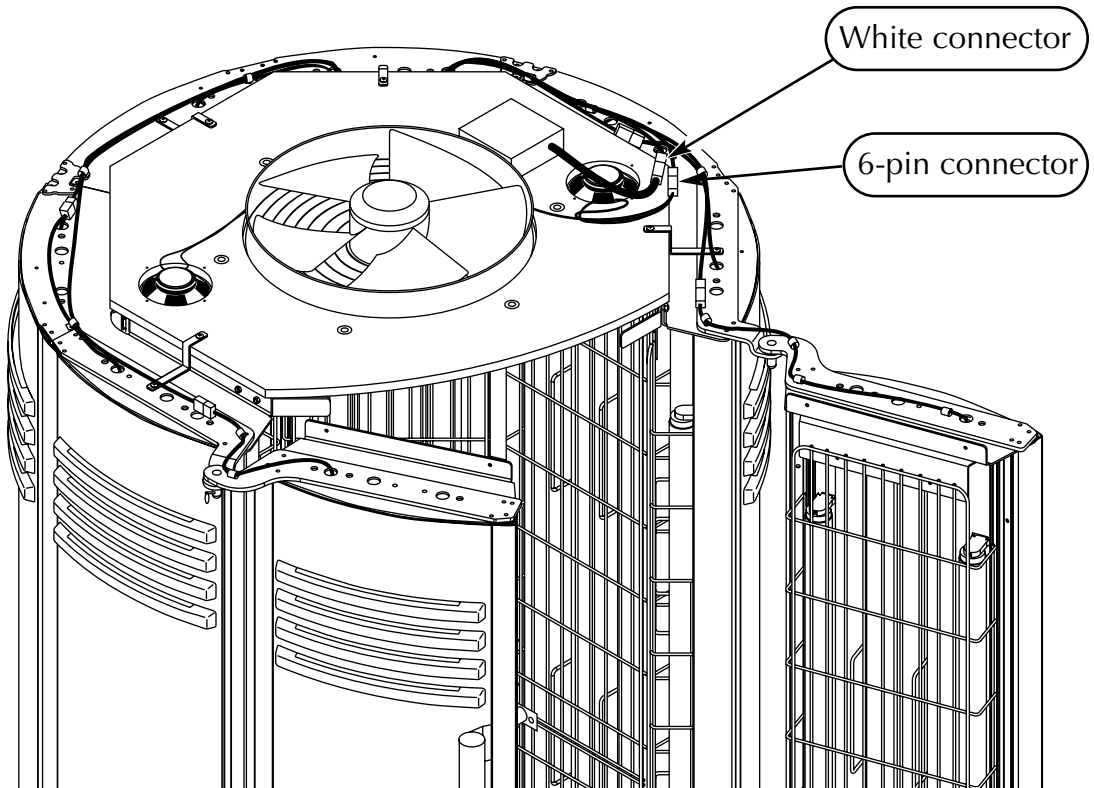



Parts needed:

Dome (box 7)

4 - #10 x 1/2" screws

4 - #10 flat washers

Secure the dome in place with the four screws, as shown. Be sure not to pinch any wires.

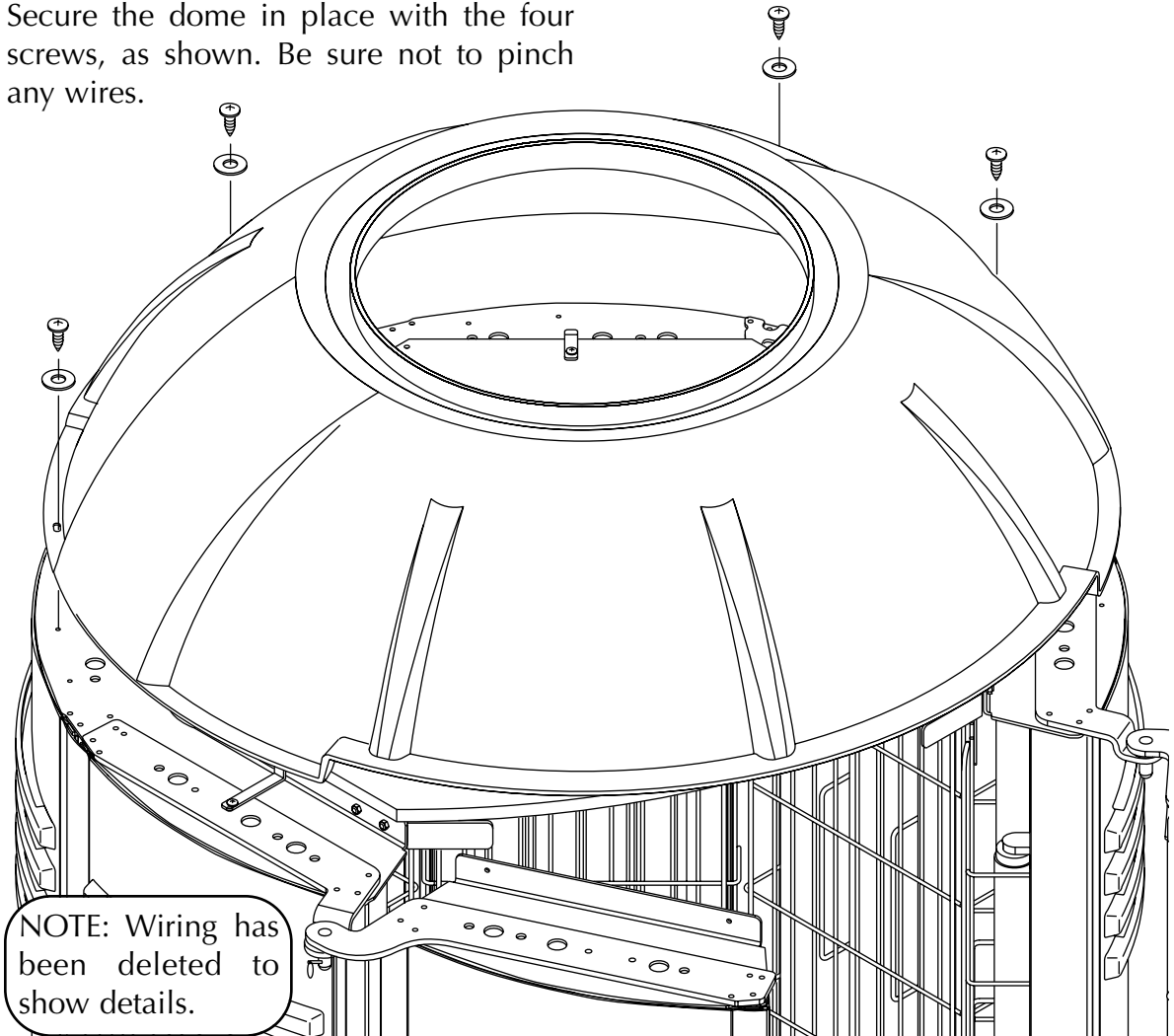



## Electrical Connections

At the rear of the booth is an armored power cable. Connect power cable as described in *Pre-Installation Planning*. Again, a professional electrician is recommended. A Remote Control Bypass plug is already installed in one of the remote control ports as shown. It may be installed in either port. Your booth will not operate without the Remote Control Bypass plug or a remote system connected. Your equipment is now ready for use.

In the dome of the booth are two speakers capable of handling 25W of musical power, with a maximum of 80W. Just above the power cable are two speaker inputs to connect to a stereo.

**NOTE:** Your unit is designed to accept an input from a remote control device. The remote control is optional. If you plan on using a remote system refer to *Remote Connections*.

**ATTENTION:** Although the Remote Control Bypass plug provided with your unit will work wherever a T-Max® terminator is called for in the series, the T-Max® terminator will not work as a bypass plug. A bypass plug is needed only when your booth is operated without a remote system connected.

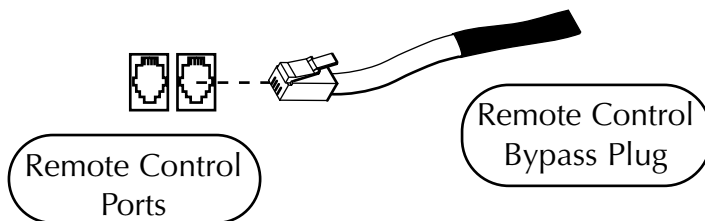



## Remote Connections

Your tanning booth incorporates advanced circuitry allowing it to connect and communicate with most remote control systems. If a remote system is to be used, first determine whether the remote system is a T-Max® System or a standard remote system operating with a control relay. Follow the appropriate instructions for your system type.

### CAUTION

The remote connection is not designed to supply or accept high voltage, nor can it provide power to an external timer. The booth's remote interface circuitry operates on 5 volts, attempting to connect it to any higher voltages will damage the unit as well as void your warranty.

**Go straight to the source with all your T-Max® brand remote questions:  
(417) 338-5101**

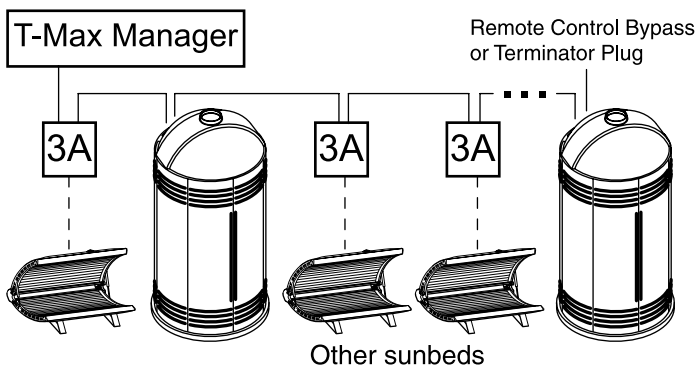

figure 1

## T-Max® Products

The T-Max® remote systems offer the ultimate in sunbed control, while allowing the tanner easy straightforward operation. Your booth is configured to directly connect to this system. The circuitry inside your booth eliminates the need for the T-Max® 1A or 3A when connecting to the T-Max® Manager series. Your booth supports the auto addressing feature of the latest T-Max® Manager models and the following parameters: 2, 5, 6, 7, 8, 9, 10, 14, and 15. See your T-Max® manual for descriptions of these parameters and how they function.

## T-Max® Manager Remote System

This system is ideal for multiple sunbed installations. Simply connect the RJ-22 modular cable(s), described in the T-Max® Manager manual, into the remote port(s) located on the back of your booth and follow the instructions that came with your remote system, noting *figure 1*. If you have an older T-Max® Manager that doesn't support auto addressing, set the address, or "id", of each unit manually as described in *Setting the address manually*. You can place your booth at any location in the series.

NOTE: A T-Max® 1A can be substituted for the 3A in figure 1.



### T-Max® 1A and 3A Remote Systems

In single sunbed installations, the T-Max® 1A and 3A can offer the same control as the T-Max® Manager, eliminating the need for a Manager. If you're using a 1A in this manner, it must have a chip labelled "master" installed on its circuit board. The remote control bypass plug must not be used in this configuration. The 3A may be used as a "master" with no modification.

After you have set the T-Max® 1A's, or 3A's, address to "0" (refer to your T-Max® user's guide) and the booth's address to "1" (see right), simply connect the RJ-22 modular cables, described in the T-Max® user's guide, directly into either port located on the back of the unit and either port on the back of the T-Max® 1A or 3A. See *figure 2*.

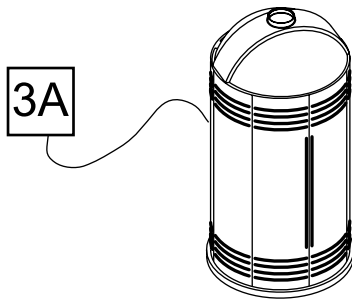

figure 2

NOTE: A T-Max® 1A with a "master" chip can be substituted for a 3A in *figure 2*.

### Setting the address manually

Before connecting your booth to the T-Max® Manager or T-Max® 1A or 3A, the address of your booth must first be set. Set the "id" manually as described below.

#### Setting the Address

1. Make sure the booth display is showing "0".
2. Press the red stop button and, without releasing it, press the green timer button and hold both for three seconds. The display should indicate an address number from "1" to "255".

1-99

100-128 (blinking dot)

252-255 (blinking dot)

3. If you are using a T-Max® 1A or 3A as a "master" remote, the address of the booth must be set to "1". If you are using a T-Max® Manager each sunbed must be assigned a different address. To adjust the address, press the green timer button to count up until the desired number (from 1 to 128) is achieved. Addresses 252 to 255 are not normally used.
4. Press the red stop button to return to the normal display mode.



### Remote systems using a Control Relay

Most non-T-Max® remote systems control the unit by the use of a relay. The relay operates the unit by connecting and disconnecting a pair of wires leading from the unit. Refer to the user’s manual provided with your remote system to determine if it operates in this way. To connect your booth to this type of system a remote interface kit is required. Contact your place of purchase to obtain the kit. *Figure 3* details a typical connection. Follow the instructions provided with the kit and from the remote’s manual to make the necessary connections.

**CAUTION**

The remote connection is not designed to supply or accept high voltage, nor can it provide power to an external timer. The booth’s remote interface circuitry operates on 5 volts, attempting to connect it to any higher voltages will damage the unit as well as void your warranty.

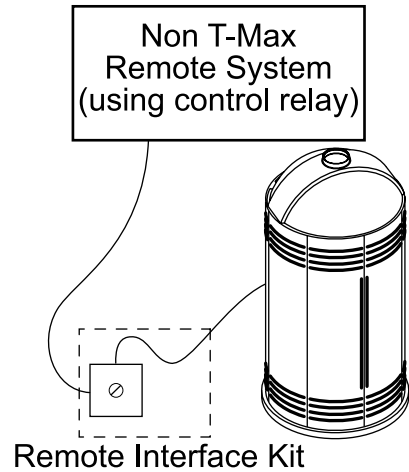

figure 3



## Before You Tan

Please note the following warnings and precautions before using your tanning booth.

- Your skin should be free of cosmetics, tanning oils, or other body lotions prior to tanning except for those specifically made for use with tanning devices. However, do not remove natural body oils by bathing or showering immediately before tanning.
- This unit intended for individual use. Only one pair of eyewear is included.

## Exposure Times

Follow the guidelines for skin type and exposure times as shown in the table below. Untanned persons should not tan on consecutive days during their first week of tanning. Never tan more than once a day. Tanning normally appears after the first few sessions and maximizes after approximately four weeks. Tan once or twice per week thereafter to maintain appearance. Persons already having a base tan may begin at advanced levels corresponding to the extent of their base tan.

### DANGER

Some medication may increase your sensitivity to ultraviolet light. It is recommended that you consult a physician before using this equipment if taking any medication or if you suspect that your skin might be especially sensitive to sunlight.

### DANGER



Shock hazard.  
Do not operate this device near water or while you are wet.

## RECOMMENDED EXPOSURE TIMES IN MINUTES

## MAXIMUM EXPOSURE TIME IS 12 MINUTES

Skin Type:	Level 1/Week 1 1st-3rd Sessions	Level 2	Level 3	Level 4	Subsequent Maximum
I <b>Sensitive Skin</b> (Burns easily and severely and does not tan.)	<b>NOT RECOMMENDED FOR TANNING</b>				
II <b>Light</b> (Burns easily and severely and tans minimally.)	2	4	7	10	12
III <b>Normal</b> (Burns moderately and tans average.)	3	6	9	12	12
IV <b>Dark</b> (Burns minimally, tans easily and above average.)	4	7	10	12	12



## Using Your Booth

When connected to the T-Max® Manager or T-Max® 1A or 3A.

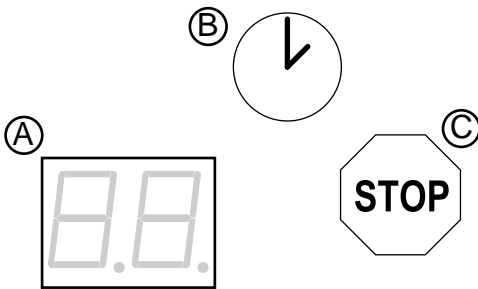

- A Timer display** - Displays remaining time.
- B Timer button** - Turns unit on. Timer display shows remaining time. If a lesser time is desired, press timer button until desired time is displayed.
- C Stop button** - Interrupts tanning session.
1. Open the doors, step inside and close the doors fully. For best results, position your body in the center of the booth.
  2. Put on your safety goggles.
  3. Assuming the remote system has been set to allow a pre-tanning delay time, the timer display (A) will repeatedly flash the delay symbol "dL" and then the remaining delay time. Press the timer button (B) or wait until the delay time has expired to begin the tanning session. The lamps will turn on and the timer will begin to count down.
  4. If a tanning time less than the displayed time is desired, repeatedly press the timer button (B) to decrease the remaining time.
  5. When the timer reaches 0 the lamps turn off. If you want to stop your session before time expires, press the stop button (C).
  6. Exit the booth. If you become disoriented there are "EXIT" signs over the doors. The cooling fans run for a period of time after the lamps shut off to aid in cooling the booth. The timer will indicate ".." as a reminder to clean the tanning surfaces. After the booth is cleaned, press the timer button and the display will return to "0".

### WARNING

**Wear protective eyewear.**  
**Failure to may result in severe burns or longterm injury to the eyes.**



## Using Your Booth

When used as a stand alone unit or when connected to a remote system using a control relay.

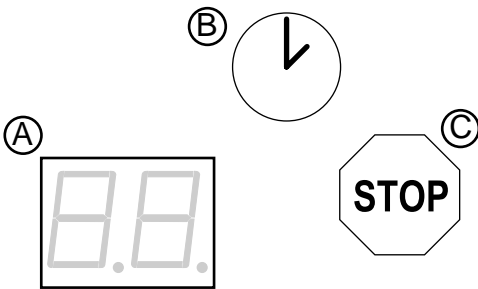

**A Timer display** - Displays remaining time.

**B Timer button** - Turns unit on. Timer display shows remaining time. If a lesser time is desired, press timer button until desired time is displayed.

**C Stop button** - Interrupts tanning session.

1. Open the doors, step inside and close the doors fully. For best results, position your body in the center of the booth.
2. Put on your safety goggles.
3. Press the timer button (B) to begin the tanning session. The lamps will turn on and the timer will begin to count down.
4. If a tanning time less than the displayed time is desired, repeatedly press the timer button (B) to decrease the remaining time.
5. When the timer reaches 0 the lamps turn off. If you want to stop your session before time expires, press the stop button (C). You will have ten seconds to restart with the remaining time, otherwise the timer will reset to 0.
6. Exit the booth. If you become disoriented there are "EXIT" signs over the doors. The cooling fans run for a period of time after the lamps shut off to aid in cooling the booth.

### WARNING

**Wear protective eyewear.  
Failure to may result in severe burns or  
longterm injury to the eyes.**



## are and Maintenance

---

### Cleaning After Use

Clean and disinfect your tanning booth's grills, handles and pedestal after each use. Use a non-abrasive disinfectant cleaner. Wipe the grills with a soft cloth dampened with disinfectant and wipe dry with a clean soft cloth. We recommend SunQuest® disinfectant and SunQuest® acrylic cleaner.

### Thorough Periodic Cleaning

#### **Introduction**

The cooling fans draw air through the unit and over time will cause a dust buildup on the lamps and reflectors. This will reduce the tanning effectiveness of the booth. When a dust buildup is observed, it is necessary to thoroughly clean the inside of the unit.

#### **Cleaning the Booth**

- Step 1** Remove the metal grills and lamps as described in *Lamp and Grill Maintenance*.
- Step 2** With a soft cloth, wipe the entire length of each lamp to remove any film buildup.
- Step 3** Thoroughly clean grills with a disinfectant cleaner.
- Step 4** Wipe the reflectors with a clean damp cloth.
- Step 5** Re-install the lamps and grills.





## Hour Counter

The SUNVISION Elite™ 48V incorporates an ingenious hour counter function into the timing circuitry. It allows the operator of the unit to monitor the hours of use of the lamps, making it easy to determine when to change them. You may also decide to use this function to monitor other time based maintenance tasks.

To determine how many hours the unit has been in service (since the last reset of the hour counter memory), first make sure the timer display shows “0”. Then simply hold the stop button for three seconds. The display will show two pairs of numbers which indicate the number of hours of service, then return to “0”. (example: Display shows 08 then 54. This equals 854 hours.) NOTE: If the unit is connected to a T-Max® remote device, it may briefly lose communication with the remote. This is normal.

To erase the indicated hours disconnect power from the sunbed. Press and hold the green timer button as you reconnect power. Release the button after a few seconds.

## Mechanical Inspection

Your tanning booth has been built for years of service. To ensure trouble-free operation throughout its life, inspect the unit's mechanical integrity every 400-500 hours of use.

- Inspect the unit's fasteners verifying that all are firmly in place.
- Inspect door hinges for signs of wear. If your hinges squeak you need only replace the bronze bushings. See *Troubleshooting*.
- Inspect the AC power cord and its connections.



## Lamp and Grill Maintenance

### Introduction

To be assured of maximum tanning effectiveness, change lamps after approximately 800-1000 hours of use. Tanning will continue after this time but at a slower rate. To ensure trouble-free operation of your booth, replace the lamp starters whenever the lamps are replaced.

	<b>⚠ WARNING</b>
	<b>Shock hazard. Disconnect power before removing any protective covers.</b>

### Removing/Replacing Metal Grills

The metal grills are secured in place by two screws at the top of each grill. Simply remove these screws and lift the grill out of its channel at the bottom. Repeat for the other grills. The long inside handles will also need to be removed to remove the left and right module grills. The lamps are now exposed.

After changing the lamps, replace the metal grills by reversing the directions.

### Removing/Replacing Lamps

After removing the metal grills, replace lamps as follows.

- Step 1 Grasp the lamp at one end and at the middle and turn the lamp one quarter turn. Gently remove the lamp from its holders.
- Step 2 Reinstall the lamp by inserting the pins located on the ends of the lamp into the slots on top of the lamp holders and turn the lamp a quarter turn. It should click in place.

### Recommended Replacement Lamps

We recommend using the lamps specified below. Use of uncertified lamps is a violation of Federal regulations and will void your warranty. These lamps have an average life of 800-1000 hours of effective tanning use. Lamps used longer than that begin to lose their effectiveness even though they continue to light.

**THE FOLLOWING LAMPS HAVE BEEN CERTIFIED FOR USE IN THIS EQUIPMENT:**

**BRONZING SUN™ Wolff® Model BS71-T12-160W VS-R BI-PIN**



# Troubleshooting

Problem	Solution
Unit not tanning	<ol style="list-style-type: none"> <li>1. Clean unit, see <i>Thorough Periodic Cleaning</i>.</li> <li>2. Ensure supply voltage is between 208 and 230V AC.</li> <li>3. Replace lamps if lamp hours are greater than 800hrs.</li> </ol>
Lamps fail to light and timer display is blank	<ol style="list-style-type: none"> <li>1. Make sure the unit is connected to a power source.</li> <li>2. Check source of AC power. Reset circuit breaker or replace fuse.</li> </ol>
Timer display changes to indicate a tanning time after the timer button is pressed but lamps do not come on	<ol style="list-style-type: none"> <li>1. Bypass plug is not installed, see <i>Electrical Connections</i>.</li> <li>2. A non-SunStar® bypass has been used. See <i>Electrical Connections</i>.</li> <li>3. If remote is being used, other than T-Max® Manager, the external timer may not be activated.</li> <li>4. Remote wiring is incorrect, see the instructions provided with the remote interface kit.</li> </ol>
My booth is connected to the T-Max® Manager remote system and when the delay time has expired the timer display starts counting down but the tanning lights do not come on	<p>The auto start feature of the remote system is disabled, see the instructions provided with your remote system.</p>
My unit won't work with the T-Max® Manager remote system	<ol style="list-style-type: none"> <li>1. The unit must first be set to a unique address, see <i>Remote Connections</i>.</li> <li>2. The bypass or terminator plug may be installed in the series in an inappropriate location. Remove the bypass plug when using T-Max® products.</li> </ol>
Timer display continues to show a 0 after the timer button is pressed	<ol style="list-style-type: none"> <li>1. T-Max® Manager remote system has not yet been set.</li> <li>2. Unit address is not set correctly, see <i>Remote Connections</i>.</li> </ol>
The last minute of tanning time does not count down from 59 seconds, but some time less than 59 seconds	<p>If the timer button has been pressed to decrease tanning time during the session, the time expired in the current minute is subtracted from the last minute.</p>

<b>Problem</b>	<b>Solution</b>
My unit is connected to a T-Max® remote system but I am having trouble getting into “id” mode	You have probably attempted to connect your booth to the remote system already. Disconnect the remote plug(s) from the ports at the back of the booth, wait 90 seconds and try again.
My unit, connected to a T-Max® Manager, did not display “dL” but does indicate: “0”  a tanning time and the lamps have come on a tanning time but the lamps have not come on	<ol style="list-style-type: none"> <li>1. Remote device has not been set.</li> <li>2. The unit has not been connected to the remote system, see <i>Remote Connections</i>.</li> </ol> <ol style="list-style-type: none"> <li>1. Delay time of T-Max® Manager has not been set.</li> <li>2. Delay time has expired and session has begun. Auto start function of T-Max® Manager has been turned off. Press the timer button to turn on lamps.</li> </ol>
When auto-addressing the first bed does not register an “id”	When using the auto address feature of the T-Max® Manager you must wait 10 seconds from the time you start the auto address function before addressing the first bed.
When using a T-Max® 1A my unit won't function properly	SunStar® Bypass plugs or terminator plugs may be needed if the T-Max® 1A and the unit are over 100 feet apart. Install the plugs in the open remote port in the unit and the T-Max® 1A.
I forgot what address, or “id”, I set my booth to	By pressing the stop button and then the timer button, and holding both for 3 seconds, the timer display will show the booth's address number. Press the stop button to exit address mode.
My salon suffers frequent, short power outages and clients complain about losing session time	If you have a T-Max® Manager, changing parameter 23 from “0” to “1” will allow the tanning bed to remember how much time was left when power goes out and resume its session after power is restored. Consult your T-Max® Manager manual for information on setting parameters.



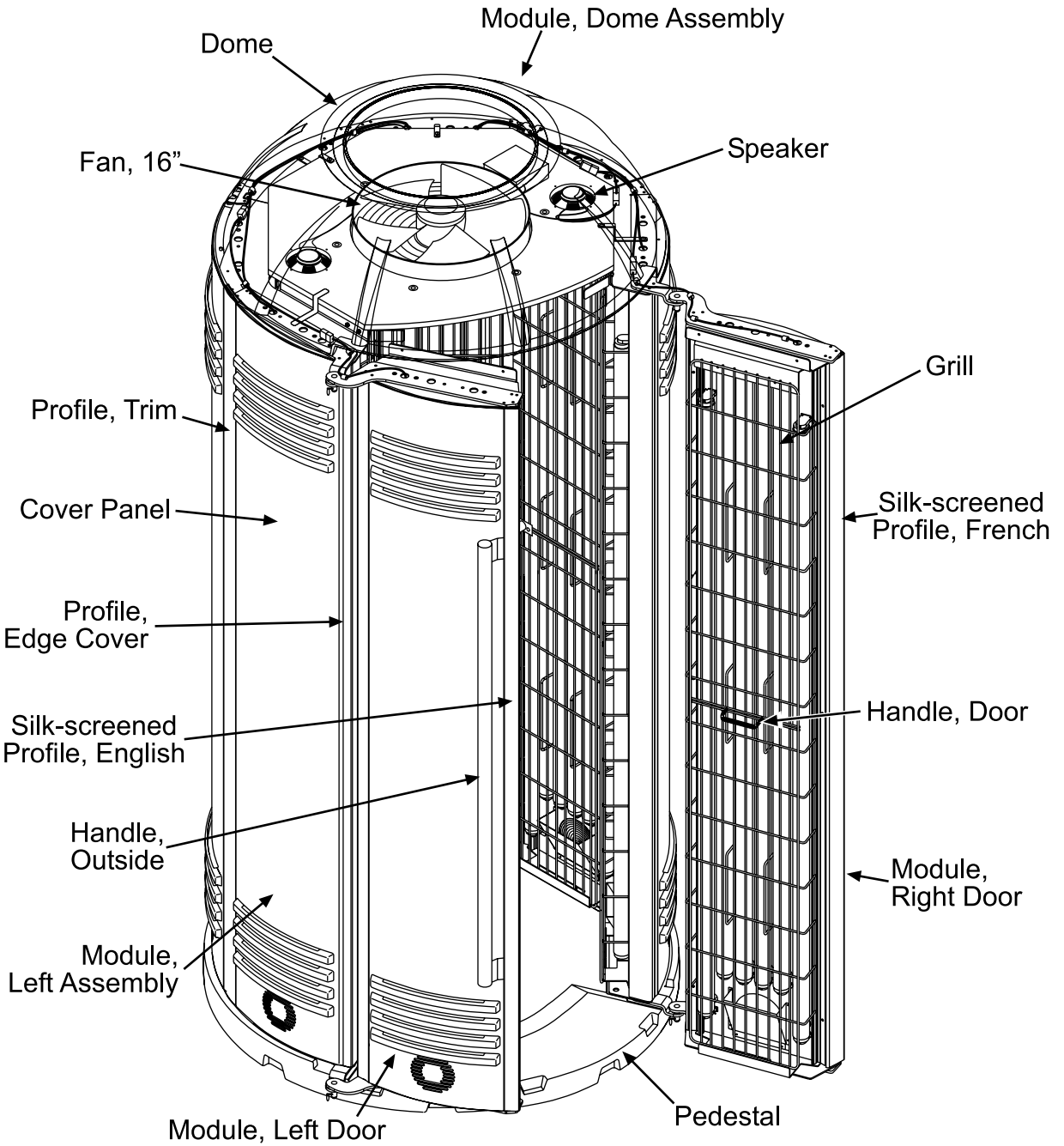

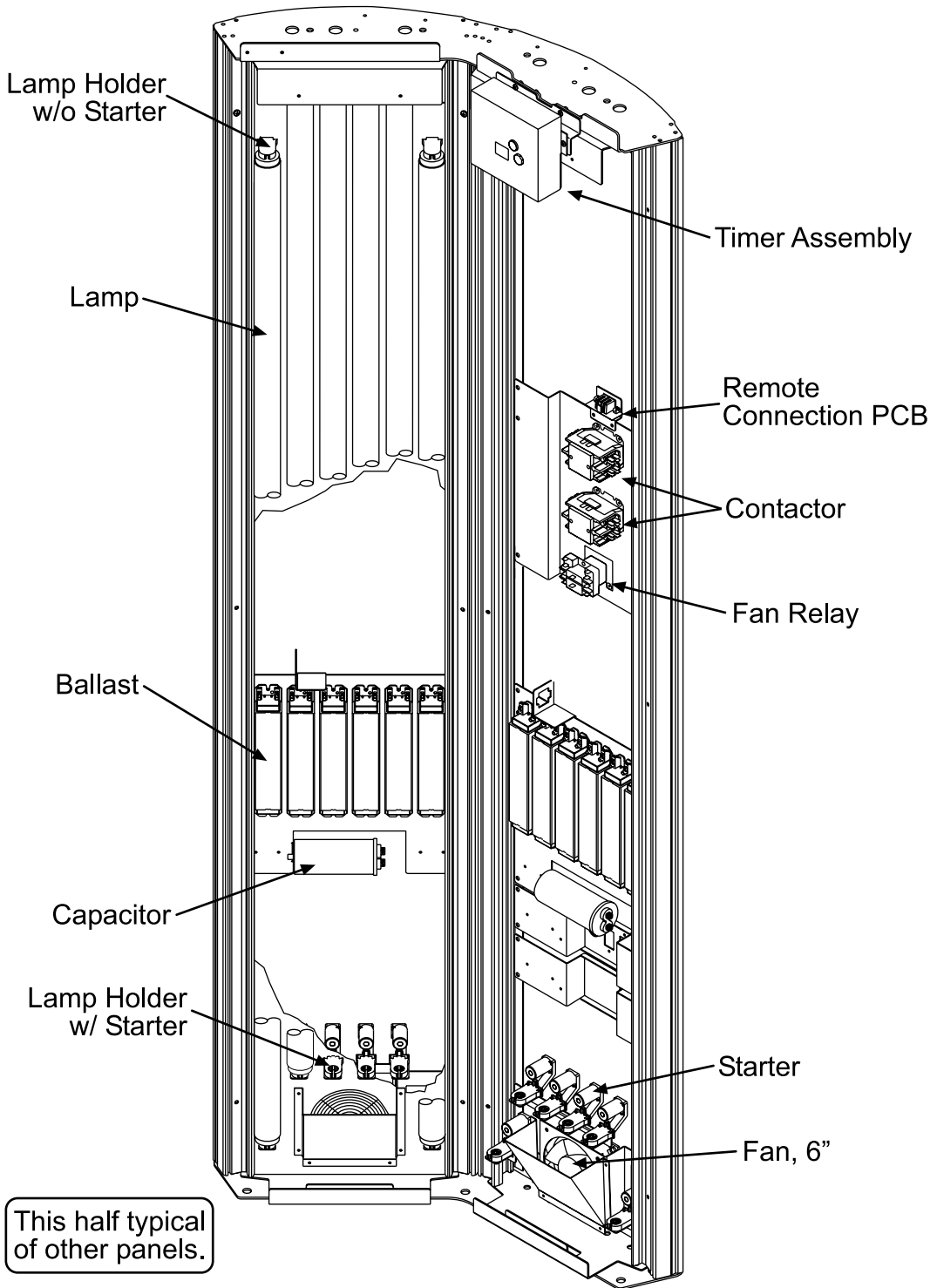

This half typical of other panels.

Module, Control Assembly shown.

# Parts List

This is a list of parts which may be replaced by the consumer. Care should be taken when replacing anything related to electrical wiring. We recommend contacting a professional electrician. When calling for parts, first state your booth model as P-48SV. Then refer to this list and preceding illustrations for proper part identification.

Air Dam\* (Foam inside cover panel)  
Ballast, 160W  
Bronze Hinge Bushing\*  
Capacitor, 75uF  
Contactor  
Cover Panel  
Cover Panel w/ Decal\*  
Cover Panel w/ Power Cut-outs\*  
Dome  
Fan, 6"  
Fan, 16"  
Fan Relay  
Grill  
Handle, Door  
Handle, Inside\*  
Handle, Outside  
Hardware Kit\*  
Hinge Locking Pin\*

Lamp Holder w/ Starter Holder  
Lamp Holder w/o Starter Holder  
Lamps  
Manual\*  
Pedestal  
Profile, Edge Cover  
Profile, Trim  
Remote Connection PCB  
Remote Control Bypass Plug\*  
Schematic Packet\*  
Silk-screened Profile, English  
Silk-screened Profile, French  
Speaker (pair)  
Starter, K-12  
Timer Assembly  
Wiring Harness, Keypad to Timer\*  
Wiring Harness, Remote PCB to Timer\*

\* Not shown

**Record this information for ease of service:**

**Date of purchase:** \_\_\_\_\_

**Serial number:** \_\_\_\_\_

# SUNVISION Elite™ 48V

Size

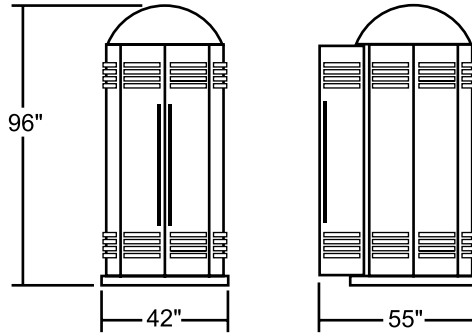
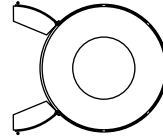

<b>Weight (Pounds)</b>	970
<b>Recommended Room Size</b>	6' x 6'
<b>Electrical -</b>	
Voltage (AC)	220
Amperage	45
Circuit Breaker (Amps)	60
Outlet	Hardwire
<b>Main Lamps</b>	<b>BRONZING SUN™ 160W</b>
<b>Ballasts</b>	160W
<b>Body Cooling System</b>	16" overhead fan
<b>Timer System</b>	Digital
<b>Max. Exposure Time</b>	12minutes
<b>Back-up Timer</b>	On-board "Watchdog"
<b>Remote Capability</b>	T-Max® compatible



Proudly manufactured  
in the U.S.A.

